



**STANEQ**

**FEEDER**

**TENNIS BALL MACHINE**

**USER MANUAL**



## TABLE OF CONTENTS

Security Warnings .....	3-5
Parts of the machine .....	6-7
Before First Use .....	8
Unboxing .....	8
Caution .....	9
Storage .....	9
Maintenance .....	9
Transportation .....	10
Battery And Charging .....	10
Battery Replacement .....	10
Charger .....	11
Charge The Battery .....	11
External Battery .....	11
AC Adapter .....	12
Usage .....	13
Control Panel Interface Introduction .....	14
Remote Controller .....	15
Tennis Balls .....	15
Customer Care .....	16
Support .....	16
Warranty .....	16
Warranty Method .....	16
Warranty Conditions .....	17
EC Declaration Of Conformity .....	18

## SECURITY WARNINGS

This tennis ball machine is designed and tested to ensure safe play, provided that it is used in accordance with the following safety warnings. Failure to follow below instructions may result in serious personal injury or property damage.

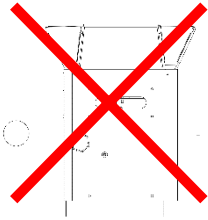

- Stay away from the front of the machine
- where the ball is out.
- Keep clear of the ejection point. Do not stand in front or near the mouth of the machine. Balls may eject unexpectedly.
- Keep children away from the machine
- while the machine is running.
- Keep people with physical and mental disabilities away from the machine while the machine is running
- Adult supervision is recommended at all times.
- Do not put your hand or foreign objects in front of the machine.
- If the ball gets stuck and the ball gets inside, cut off the electricity of the machine and take the ball after the rotating parts stop.
- Never touch the spinning wheels.
- Do not put your hand in the rotating part in the ball hopper, do not try to place the balls , do not interfere.
- It can be dangerous and harmful if things (clothes, hair, fingers, etc.) enter the rotating part of the ball hopper.



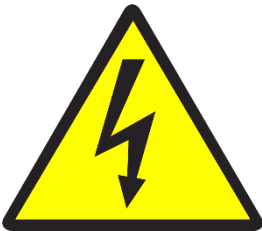

- Do not put new ball while the machine is running and the rotating part in the ball hopper.
- The machine should not be used in wet conditions and rain.
- Keep away from water.
- Keep the machine in dry environment.
- The charger is only to be used indoors.
- Do not spray water, do not wash with water.
- Never operate the machine while the machine is charging.
- In an emergency, the lower right button on the back cuts off the power completely. (Turn it to the “0” position.)
- Wait for a while after turning off the power, the wheels may continue to spin.
- The charger is a 24V 1A battery charger. Do not plug in any other device or adapter.
- Do not apply 110v or 220v directly to the charging socket of the machine, it is dangerous.
- Do not touch the charger if it is wet, remove it after closing the general fuse (plug fuse). Also, do not reuse the wet battery and charger.
- If your machine has an internal or external battery:
- Keep sparks and flames away from the battery (i.e. no smoking)
- Do not use the battery if it has swollen or expanded.



- Only use a 24V battery with this machine (or alternative approved by your distributor).
- When replacing the battery, the terminals should be wrapped with electrical tape or a heat shrinkable sleeve.
- Use correct removal methods.
- The machine is 19 kg. Lift the machine carefully.
- The packaging box is 27 kg. (raise two people)
- Keep your machine clean. Contaminants such as dust and leaves inside your machine can pose a burning hazard. Please regularly vacuum your machine from your mouth.
- Do not use the machine in explosive atmospheres, it may generate sparks. May pose a risk of explosion.
- A multi-purpose/dry chemical extinguisher should be used to extinguish any flame.
- Use tennis ball in your machine. Do not use cricket balls it will damage your machine.
- This machine should not be used to throw any object other than a tennis ball.
- The recommended ball is a training (non-pressure) ball. Our machine is suitable for both orange (stage 2) and green (stage 3) low pressure balls. Red (Stage 1) balls of large sizes cannot work.

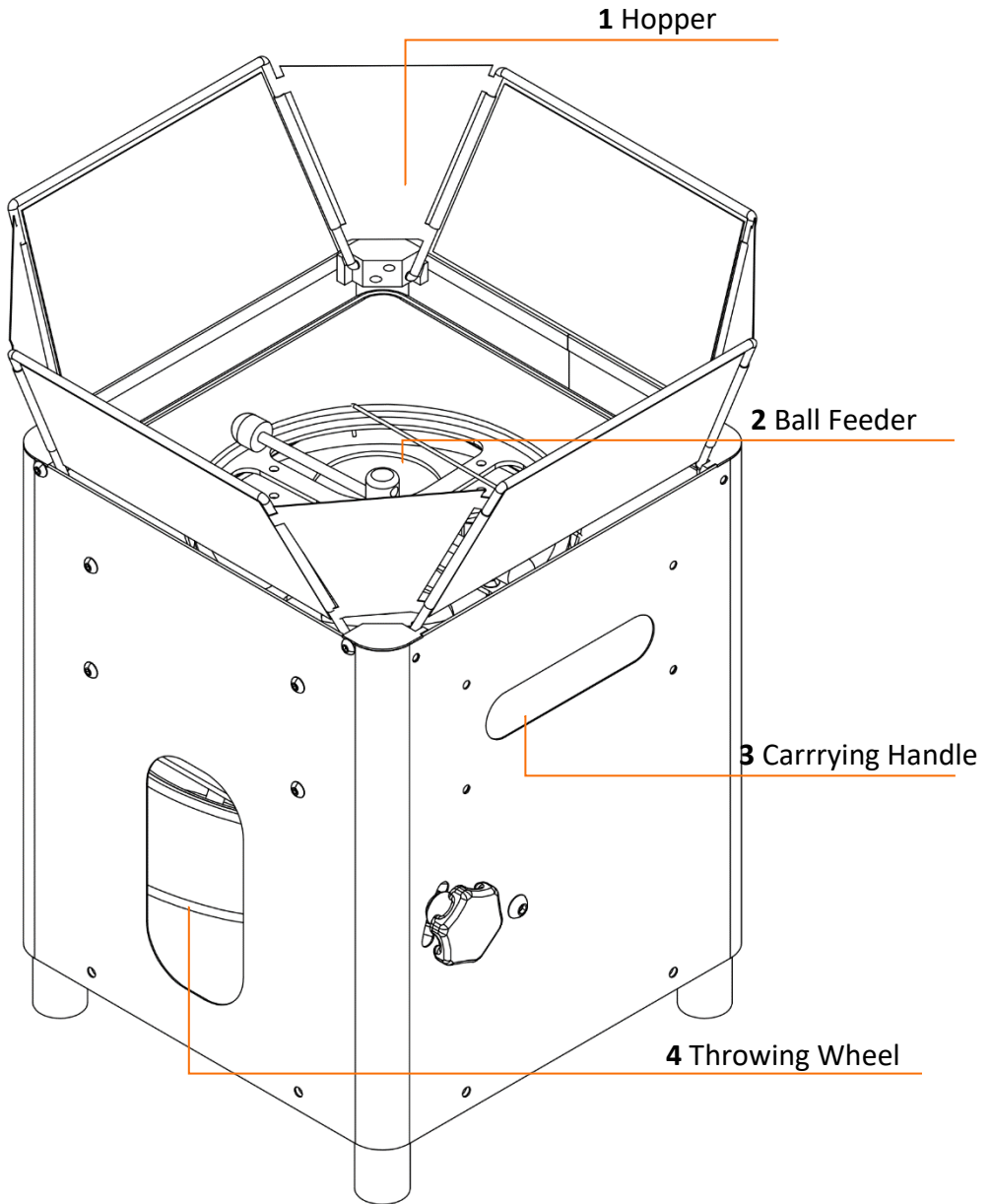

**5 Height Adjustment Lever**

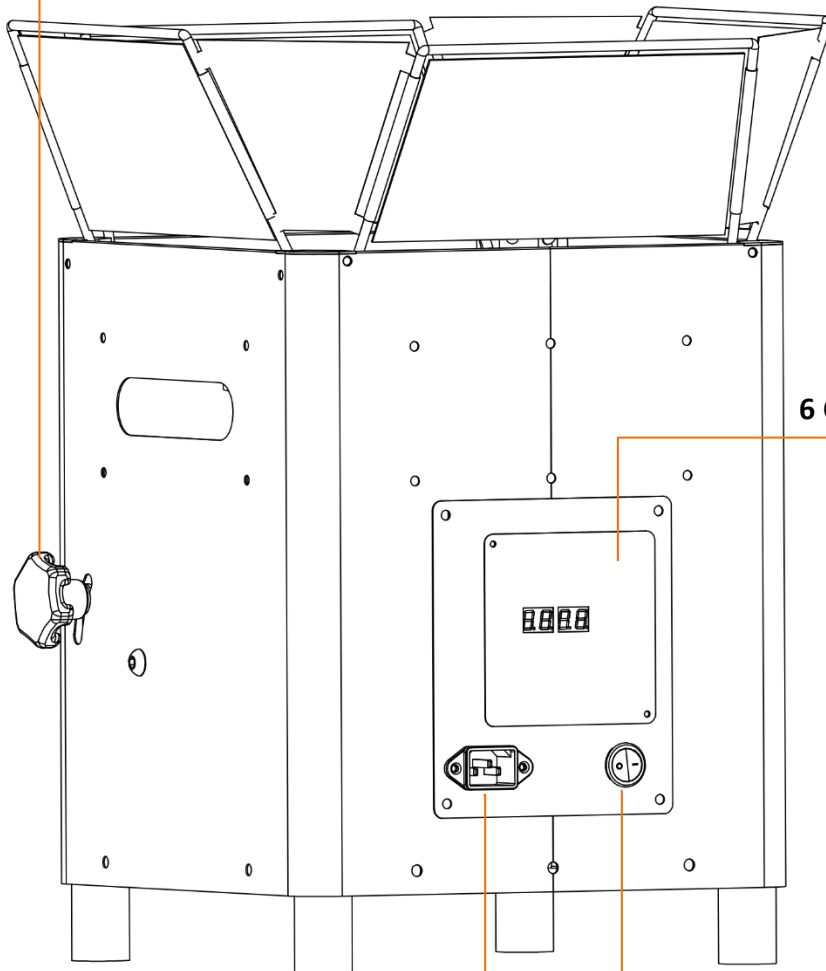

**6 Control Panel**

**7 Charging Socket**

**8 Power Switch**

## **BEFORE FIRST USE**

When you first open your box, you may notice some cosmetic scratches on your machine, especially the ball hopper on the top of the machine. This is completely normal and part of the manufacturing process.

You may also notice a yellow ball feather inside your machine or on the launch wheels. This is also normal as every machine is tested with balls as part of our quality control process (the wheels are then wiped, but all traces of ball fluff are difficult to remove).

## **UNBOXING**

Please read the entire user manual.

When transporting, carry it in an upright position.

First take out the charger from the box.

Get help from a person while taking the machine out of the box and take it out by holding the bottom plate.

Check the machine for damage that may occur during transportation.

### **Items out of the box:**

- Machine
- Charger
- Remote Controller
- User Manual

After removing all the parts, you can bring the ball chamber to its position on page 7. You can start the machine by turning the power button on the bottom right of the machine to the "1" position. You may need to return your machine to its supplier in the future, so we recommend keeping the box. Open the ball chamber by lifting it upwards.



## **CAUTION**

This machine is designed for use on the tennis court and is not to be used under any other circumstances. Only tennis balls should be used, no other balls should be thrown from the machine. Red level tennis balls should also not be used. Never stand in front of the machine unless you are on the other side of the tennis net (more than 7 meters away). Never stand in front of the machine, even if it is stopped, as the balls can fly at any time. Children should always be supervised and taught to never stand in front of the machine. Do not use the machine in the rain and avoid using a wet ball. It is recommended to use non-pressure balls to give your machine the best performance. Using a combination of new and old balls will produce inconsistent results.

## **STORAGE**

We recommend storing your machine in a closed area, preferably with the cover closed for protection. Do not expose your machine to rain, even with the cover guard, as rain can damage your machine. Do not expose your machine to direct sunlight and keep it on its rubber feet. Do not position it sideways or upside down. Keep your machine away from explosive atmospheres, do not store it in high temperature environments.

## **MAINTENANCE**

At the end of 3-4 workouts, with the machine turned off, clean the dust and fluff inside with the help of the vacuum machine from the mouth part. The outside of the machine can be wiped with a soft damp cloth, but please be careful not to get water inside the machine. During maintenance, the grounding chain, machine components and connecting parts (bolts, nuts, etc.) must be checked and robust. Also, with heavy use, the ejector wheels and batteries may need to be replaced. If you play on clay or a very porous surface, we recommend wiping the inside of your launch wheels once a month (clay build-up can cause your wheels to become unstable).

## TRANSPORTATION

Never move the machine while it is power on. Please ensure that the machine is always upright. Putting it on its side may cause damage and void your warranty. Do not store the machine in your car when the temperature exceeds 30 degrees.



## BATTERY AND CHARGER

**Attention! Never press the power button while the machine is charging! The charger is not for starting the machine. It works with the battery inside the machine!**

The charge of your machine should take between 3-8 hours depending on the settings you use. Follow the battery information from the indicator at the top left of the phone program. Do not use and charge when the indicator drops below 10%. Even if you do not use the machine, you must charge it once a month, otherwise the battery may deteriorate.

## BATTERY REPLACEMENT

Only replace with a 25.6 Volt LiFePO (8 series 3.2V) battery. Please use electrical tape or something similar to cover the battery terminals. Do not keep the battery near a source of flame or smoke. Avoid short-circuiting the battery to avoid fire. **Please do not reverse the terminals! There is no reverse polarization protection. The circuit board of your machine will be damaged and will be out of warranty.**

## CHARGER

The charger is the most suitable charger for the machine. It is normal for it to become slightly warm during charging. You should use your charger for charging in a dry environment. This charger is suitable for 8S LiFePO battery. You should use it to charge the batteries in the machine. Please note that this charger cannot be used to power the machine directly.

## CHARGING THE BATTERY

Connect the charger to the machine or external battery first. The green light will turn on. Plug the other triangle-like end of the charger into the socket on the lower left side of the back of your machine. The RED (charge) light will turn on. When the battery is full, the GREEN light (full) will turn on. Please unplug first from the socket and then the charger from the machine when the green light turns on. The filling process is expected to take 3-8 hours. **Do not plug in a different power cord (220v AC).**



## EXTERNAL BATTERY

If you bought the machine with an external battery option or later bought an external battery, please read this section. When using your battery, please **keep it away from rain, water or**



**wet ground.** It is essential that the battery case or socket never get wet. Use the external battery in a dry and closed place. Avoid prolonged exposure to the sun. STANEG and its distributors are not responsible for the problems that may arise in these and similar situations. To use with external battery, place the male end on the machine and start the machine in position 2(II). To charge, place the male end of the charger on the female end of your external battery. **Do not charge your external battery while it is plugged into the machine.**

### **AC ADAPTER**

If you want to use the machine with an AC adapter, obtain it from STANEG or its distributors. When using the AC adapter, **please keep it away from rain, water or wet ground.** Never get the AC adapter or socket wet. Use the adapter in a dry and closed place. Avoid prolonged exposure to the sun. STANEG and its distributors are not responsible for the problems that may arise in these and similar situations. To use with AC adapter, first plug the adapter into the socket, then insert the socket part into the machine and start the machine in position 2(II).

## USAGE



The machine can be placed just behind the so-called center mark on the court, but placed elsewhere to create different workouts. Please add the balls to the hopper before starting, do not add the balls while the agitator is rotating, otherwise it may cause ball jamming. The maximum capacity is 150 balls. Please do not overfill the hopper as excess weight may damage the feed motor.

Press the power button of your machine. If you are using the internal battery, set it to position 1(I), if you are using an external battery or AC adapter, set it to position 2(II) and start the machine.



Select speed, ball frequency settings.

To start, press the start button on the top right.

Speed: Allows the ball to be thrown faster or slower.

Frequency: Sets the ball to be thrown with a frequency of 2-10 seconds.

Vertical: You can manually change the vertical angle with the side adjustment lever. You need to tighten the adjusting lever well, otherwise the vertical angle will deteriorate as the ball is thrown.

## **CONTROL PANEL INTERFACE INTRODUCTION**

On the instrument panel b. the part that continues with the expression is the percentage expression of the battery fullness indicator of your machine. It can measure with an error of +10 -10, this is normal.

In addition, when the ball toss starts, the expression "PLA", that is, play takes place.

The start button on the top right is for starting and stopping the workout.

4 different orange gray keys determine the speed and frequency of the ball in the training in turn.

## REMOTE CONTROLLER

You can change the speed setting with your remote control, and you can also start and stop your training.

Increase speed with the A key

Decrease speed with the C key

Start – stop with the B key

Start - stop with the D key

You can do the operations.



Your remote uses 433 Mhz radio frequency. It works at a distance that can comfortably detect the length of a tennis court. If your

remote control is not working properly, please replace the battery.

Please do not reverse polarity when changing the battery. A remote

can affect more than one machine at the same time. If you have more than one machine, you need to program it separately, in this case, please contact us.

## TENNIS BALLS

Use a tennis ball in your machine. Do not use cricket balls, it will damage your machine. This machine should not be used to throw any object other than a tennis ball. Your machine can hold 70 balls.

While the hopper can probably hold a larger amount than that, we recommend limiting it to 70 balls, which weighs less on the rotary engine. We strongly recommend using non-pressure balls, preferably from a reputable brand. Pressure cannons can also be used, but their pressure will drop over time, resulting in inconsistent shots. The machine is suitable for both orange (2nd stage) and green (3rd stage) low pressure balls. It cannot work with large red (1st stage) balls.

## **CUSTOMER CARE SUPPORT**

When calling support, please provide us with the serial number located on the base of your machine. Also, any video footage that will show the problem will greatly assist us in solving your problem. If you hear any unusual sounds, please report them and where the sound is coming from.

## **WARRANTY**

If any part fails during the warranty period due to defective workmanship or faulty materials, Staneg or its distributor will repair or (at distributor option) repair the defective part free of charge. The warranty period is country specific, please contact the Staneg distributor in your country or your dealer for details.

## **WARRANTY METHOD**

The warranty is managed by your country's authorized Staneg distributor. For the contact information of your country's Staneg distributor, please visit our website: [www.staneg.com](http://www.staneg.com) . Be sure to let us know all the details about your machine, including the serial number and model, and a detailed description of the fault, to ensure your warranty service request is processed quickly. Exposure of the ball machine to foreign matter should be minimized. Please close the cover of the machine after the game is over. Damages that cause your machine to be exposed to foreign substances are not covered by the warranty.

This warranty covers the purchaser or any other person for damage, malfunction or loss due to:

- The lack of maintenance, abuse, neglect, misuse, accident or misuse of this device.
- Makinede çizikler, oyuklar, aşınma veya genel aşınma ve yıpranma.
- Scratches, dents, wear or general wear and tear on the machine. Garanti süresi boyunca izinsiz onarımlar.



- Natural disasters.
- Use at power voltages other than those specified for your machine.

In these cases, the service is paid.

Under no circumstances shall Staneg or its authorized distributors be liable to the customer or any other person for any damages, including but not limited to personal injury or damage to property, and for any resulting damage.

### **WARRANTY CONDITIONS**

- The machine will be delivered to the Staneg distributor service department or authorized service representative and shipping charges will be paid by the owner either way. No liability is accepted for loss or damage in transit.
- The machine should always be operated and maintained in accordance with the instructions given.
- No modifications or repairs may be made without prior approval from the Distributors. Such repairs or replacements do not extend the warranty period.
- Proof of purchase must be provided to verify the date of purchase and establish the warranty period. Only the original purchaser applies under this warranty.
- The warranty period is calculated only from the date of purchase.
- In cases where this warranty does not comply with the law of the region in which it is located, the legal rights of the purchaser will be governed.
- Parts loaded from other manufacturers' products will void this warranty.



# EC Declaration of Conformity

We, 'STANEG MACHINERY MANUFACTURING INDUSTRY IMPORT EXPORT' LIMITED COMPANY declare under our sole responsibility that the machine below

**ADDRESS:** İvedikköy Mah. 1487 Cad. Emporium BC: No: 28  
Yenimahalle /ANKARA- TÜRKİYE

Machine Name:	<b>Tennis Ball Machine</b>
Machine Type:	<b>Staneg Feeder Model</b>
Year of Construction:	<b>2021</b>
Serial No:	<b>1</b>

is in conformity with the directives and the standards mentioned below:

- 2006/42/EC Machinery Directive,

Regulations Applied according to Harmonize Standards:

- EN ISO 12100-1:2010 Safety of Machinery - Basic Concepts, General Principles for Design, Part 1: Basic Terms- methodology
- EN 60204-1:2018 Safety of Machinery- Electrical equipment of machines Part 1: General requirements

Name, Surname: **Yunus Emre Tuğlu**

Position: **General Manager**

Signature:

Place: **Ankara / Turkey**

Date of Issue: **20.11.2021**